

A FEW BASIC 4017 CIRCUITS

COUNT TO TEN OVER AND OVER

In these basic 4017 circuits, use LEDs to show the output sequence.

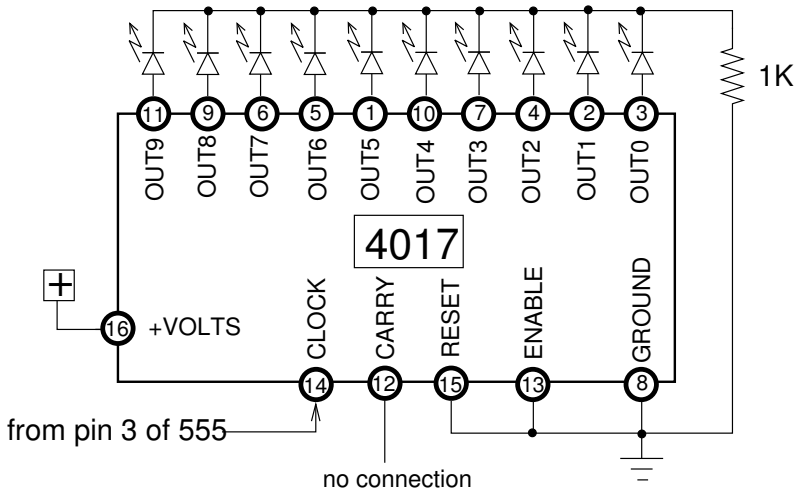

COUNT TO A NUMBER OVER AND OVER

To count to a number, add 1 to the number and tie that output to the reset pin. Making the reset pin high makes the count go back to zero. Use a 10K pull-down resistor to ground if it acts funny. In this example the chip counts from zero to three.

To count to a number and halt: Tie pin 15 (reset) to ground. Disconnect pin 13 (enable) from ground and connect it to the output pin you want to stop at.

Making the enable pin go high stops the count.

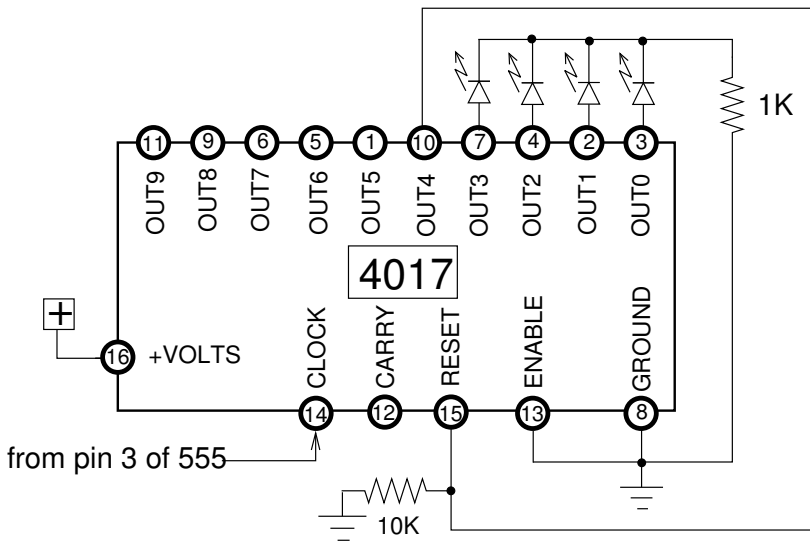

COUNTS TO 10:

COUNTS TO 100:

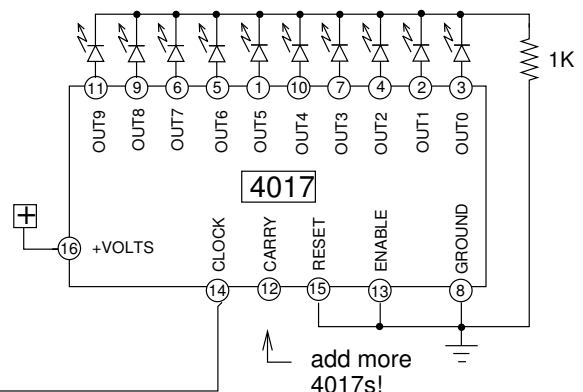
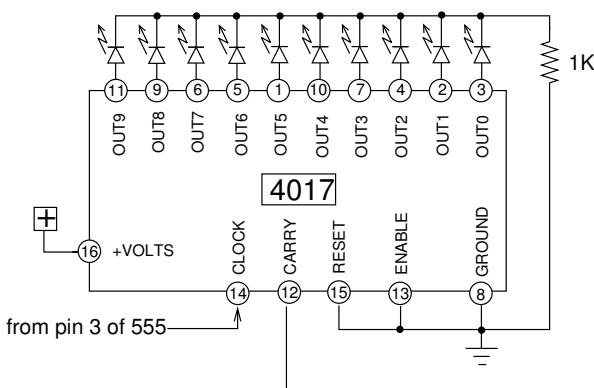

CASCADING:

Use the carry output (pin 12, aka "divide by 10 out") of one 4017 to connect to the clock of another 4017. You can keep connecting more and more chips to get a really long time delay.